



**MAKE IT MODERN!**  
Five & Six Speed Conversion Specialists!

## Stealth Series Master Cylinder Kit for 64-1/2 to 66 Mustang MD-910-3001-B and MD-910-3001-C

### Installation Instructions



MD-910-3001-B kit shown

Thank you for purchasing the Modern Driveline *Stealth Series* Master Cylinder Kit. This kit is designed to attach to the pedal hangar, leaving only the small premium billet reservoir exposed in the engine compartment for servicing and aesthetic appeal. Braided lines and bulkhead fittings seal the deal on this one!

Modern Driveline Stealth Series... This Kit is Out of Sight!

**Read These Instructions Completely Before Beginning**

## 1. Before You Begin

- 1.1. This kit will require some disassembly of the vehicle to install.
- 1.2. General vehicle mechanical knowledge and an understanding of the terminology are required to install this kit.
- 1.3. **DO NOT VACUUM OR PUMP BLEED THIS SYSTEM.** It is not brakes. Single seal push-pull systems will create micro bubbles in the fluid and in some instances harm the seals internally. The preferred method is to pressure bleed from the top down. Modern Driveline offers a hydraulic clutch system “bleeder kit”. The bleeder kit comes standard in all Modern Driveline master cylinder kits and is also available separately as a purchase item.
- 1.4. These systems are DOT 3 or DOT 4 brake fluid compatible. Do not use DOT 5 silicone based, or any high temperature resistant brake fluids designed for more than 550°F as some brands will cause the seals to swell.

## 2. Pedal Height Matters

- 2.1. Our Master kit has 3 adjustable positions for fine-tune adjustments. It is always recommended the pedal uses full-travel: Up-stop, down to carpet/floor. This will prevent damage to the cylinder.
- 2.2. All parts in this kit are designed with nominal clutch pedal height in mind. The ideal clutch pedal position will re-engage the clutch about 1/3 to 1/2 total pedal travel, up from the carpet.
- 2.3. It is not necessary for this master cylinder to use all the travel of the piston to release the clutch.

## 3. Information about this kit

- 3.1 This cylinder can travel **up to** 1.25”. Most installations will not use all the travel of this cylinder.
- 3.2 This cylinder has a 0.812” bore.
- 3.3 .812” bore x 1” stroke = .52 cu/in fluid volume requirement.
- 3.4 .812” bore x 1.2” stroke = .62 cu/in fluid volume requirement.
- 3.5 The existing aftermarket slave cylinders typically use 0.52” cu/in fluid volume and are considered compatible with this master cylinder kit.
- 3.6 Our mock-up firewall has certain items removed for clarity.
- 3.7 Three braided lines are provided in this kit. The coated line is for the reservoir. The two uncoated lines are for under the dash; This allows for greater flexibility.
- 3.8 If installed... the black ends on the coated line may be removed.
- 3.9 **No kit substitutions.** Additional or different parts may be purchased if you choose.
- 3.10 **Do not remove** the **red cap** inside the reservoir.

## 4. NON-Warrantable Conditions.

- 4.1. Do not over-torque parts.
- 4.2. Do not over-tighten parts (non-torque valued locations).
- 4.3. Do not add parts to our kit.
- 4.4. Use all parts of this kit unless instructions are provided not to do so.

- 4.5. Do not substitute parts in this kit, contact MDL for assistance if necessary.
- 4.6. Required vehicle components are your responsibility.
- 4.7. Always check/test threads prior to installation into the vehicle. **Damaged threads are not warrantable.**

## 5. Tools, Shop Supplies, and Notes



- 5.1. Standard shop tools, 1/8" & 5/16" Allen Wrench, 11/16" & 3/4" Deep Sockets, 5/16"-24 tap.
  - 5.2. Aluminum AN Fitting Wrenches (optional) for bulkhead fittings.
  - 5.3. DOT 3 brake fluid.
  - 5.4. Dielectric grease (typically used on spark plug wires).
  - 5.5. Medium strength loc-tite (blue).
  - 5.6. Soapy water in a spray bottle (brake fluid clean-up).
  - 5.7. Safety Equipment – Always wear ANSI approved safety goggles/glasses when working with metal and fluids. Wear proper gloves when working with hot surfaces and corrosive fluids.
  - 5.8. A ground strap from the engine to the body, and body to frame, must be used.  
**Failure to install a ground strap from the engine to the body and frame will result in braided line failure. The braided line cannot be used as a ground strap.**
6. Provisional Parts – Some parts may not be required depending on pedal hangar and brake pedal configuration.
- 6.1. MDL provides (4) new pedal shaft bushings in this kit. (2) for the clutch pedal cross shaft which may not be used if you have a roller bearing kit installed, (2) that may not be used if your brake pedal functions on a different plane than your clutch pedal. Note: It is recommended to replace ALL (4) bushings if the brake and clutch pedal are all on the same plane and no roller bearing kit is installed. Cheap plastic brake pedal bushings may cause installation difficulty.

## 7. Options

- 7.1. Alternate routing of braided lines and firewall bulkhead fitting location may be used for customized firewalls. Consider reservoir placement on firewall. This kit provides parts for a factory firewall installation. Optional items may be purchased separately. No kit substitutions.

8. **Disassembly** – If your vehicle is already disassembled, verify all disassembly steps have been performed and skip to the Assembly Instructions. If you are converting from an automatic vehicle, some disassembly steps do not apply.

8.1. Remove the driver's seat and lay down some cardboard. For convenience to install the supplied MDL pedal hangar bracket... you may drop the steering column and remove the instrument cluster. Note: To avoid damage to the instrument cluster do not try to remove the instrument cluster with the steering column still in-place. Air conditioning ducts and electrical routing are to be considered.

8.2. This step applies to a vehicle with an existing mechanical linkage system. Remove the clutch fork spring, Z-bar spring @ firewall (if equipped), frame fulcrum pivot and hardware, Z-bar, upper and lower Z-bar rods, engine fulcrum pivot and hardware. Remove the spring attached to the clutch pedal under the dash (if equipped). Retain the *clutch fork spring* if using MDL's Eliminator Slave system. Temporarily remove the clutch pedal up-stop.

8.3. Disconnect and remove the brake pedal.

8.4. For automatic cars, trim down the brake pedal pad area to match the rubber pad, sold separately.

9. **Installation** - Clean as you go, use soapy water on spilled brake fluid, general cleanliness for all fitting and line-end ports.

9.1. Test threads in all holes prior to installation. Ensure fasteners thread into holes properly. Zinc plated parts may require a tap to clear the material.

9.2. Install MDL supplied Pedal Hangar Bracket on the top side of the pedal hangar using supplied 5/16"-24 fasteners. You may use medium strength blue loc-tite at this location. Note: No washers are installed at this location. Torque the bolts at this location to 15-18 ft/lbs, light wrist tight.

Note: You may choose to pre-assemble the master cylinder to the bracket prior to installation of the bracket. See instructions in the next steps.



9.3. Test fit the nylok nut to the clutch pedal cross shaft bolt to verify the threads assemble correctly.

9.4. Install the MDL supplied clutch pedal and your existing brake pedal with newly supplied pedal bushings using the supplied cross-shaft bolt and nylok nut. Holding the pedal with your hand, use a 15/16" socket to tighten the nylok nut. Once the nut bottoms out, tighten up to an additional 1/8 turn. The clutch pedal should hang freely and not be loose to the cross shaft.

9.5. Re-attach the brake pedal components per vehicle requirements.



MDL supplied clutch pedal shown installed. Cylinder and brake pedal not shown for clarity.

9.6. Install, or re-install, the pedal up-stop on the pedal hangar, sold separately.

9.7. See below picture. Attach master cylinder to the bracket. The order of washer stack-up is very important.

M/C at bracket - from outboard to inboard... bolt head, bracket, flat washer, Cylinder, lock washer, nylok nut.

You may reverse the bolt/nut orientation if you wish but to not change the washer orientation.

9.8. See below picture. Install the rod-end on the master cylinder (the jamb nut should already be installed) but do not torque or tighten at this time. There are 3 positions on the clutch pedal the rod-end can be attached to. Position the rod-end through the center of the 3 positions. There are Adjustment Instructions provided at the end.

The order of washer stack-up is very important.

M/C at pedal - from outboard to inboard... bolt, pedal, flat washer, rod-end, nylok nut.

Do not reverse the orientation of the hardware at this location. The non-threaded portion of the shank at this location will provide better support going through the pedal.

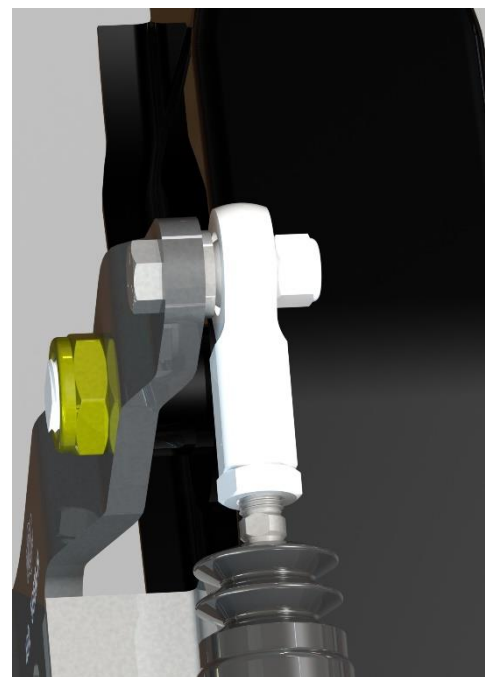

Left Photo Shown: bolt head, bracket, flat washer, Cylinder, lock washer, nylok nut.

Right Photo Shown: bolt head, pedal, flat washer, rod-end, nylok nut.

9.9. Torque the bolt/nut at these locations to 15-18 ft/lbs, light wrist tight.

9.10. Cycle the clutch pedal **by hand** and check for freedom of movement. There should not be any binding and the pedal stroke freely. The rod inside the cylinder may be rotated using the two flat spots on the rod and a 5/16" wrench, or the rod may be rotated by hand; The rod will have some resistance.

**DO NOT PRELOAD THE MASTER CYLDINER ROD; doing so will not allow you to bleed the system.** Rotate the master cylinder rod so the pedal is against the up-stop and tighten the jamb nut against the rod-end, light wrist tight.

9.11. Re-check for freedom of movement. The pedal should stroke completely to the floor and come against the up-stop.

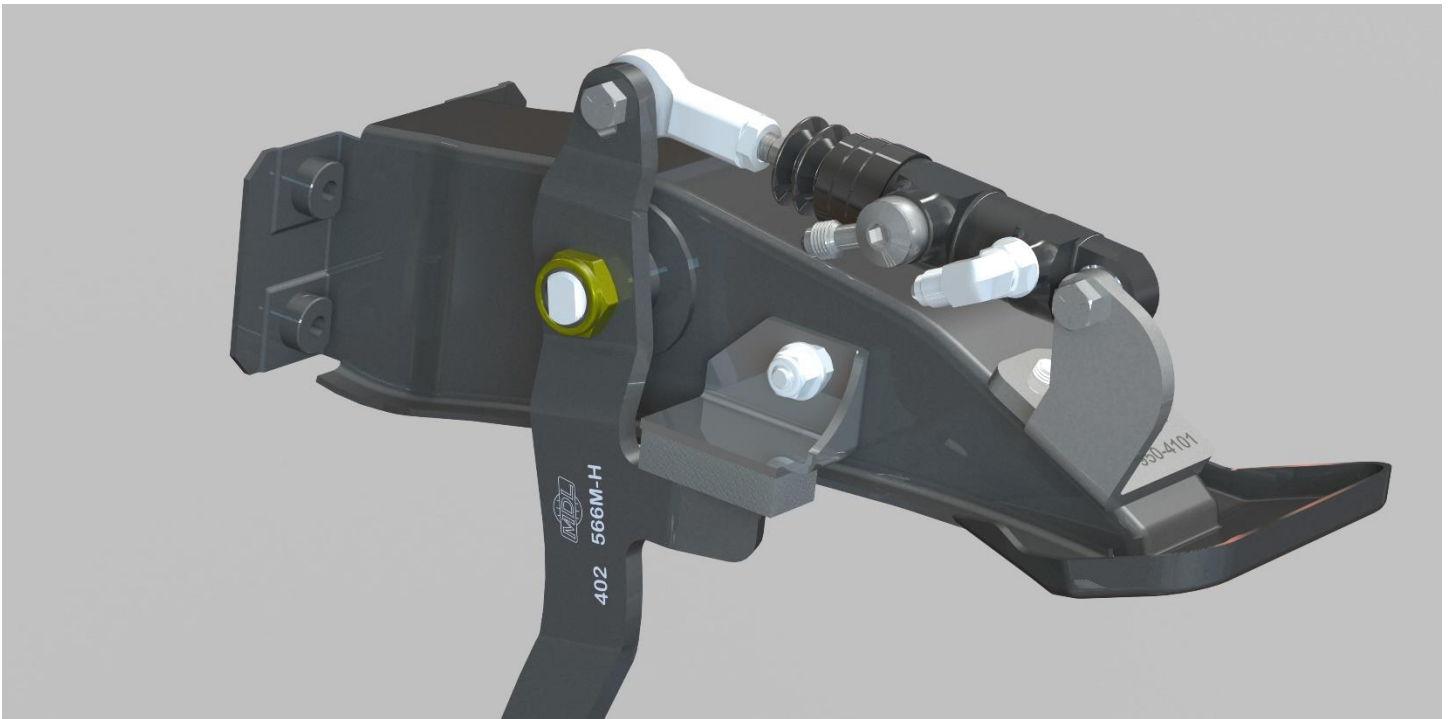

9.12. See above and below pictures. Position the master cylinder fittings approximately as shown. The banjo fitting is the reservoir port, and the small elbow fitting is the pressure port. Do not completely torque at this time but do not leave loose. Due to limited access, it would be best to install the line and fitting closest to the pedal hangar first. This can be the reservoir or pressure port, depending on how you would like the engine compartment side to appear.

Note: There is enough line length under the dash the line-ends can be swapped for position at the firewall.

9.13. The firewall plate assembly is reversible. The O-ring will always install on the black half. Prior to installing the O-ring... verify the step on the black plate fits in the clutch rod hole and the opening in the firewall is flat. Use a round edge file to clean up the opening as necessary. Apply a small amount of dielectric grease to hold the O-ring in place. Position the inner and outer firewall plates with both bulkhead elbow fittings. **The elbow ends go under the dash.** Position the fittings so they are horizontally level to each other and lightly secure the inner elbow fitting only with a jamb nut and temporarily remove the outer elbow fitting.



Position both elbow fittings, inner with a jamb nut, then remove the outer fitting.



Some assembly sequencing can vary based on tool availability. The assembly sequence noted below is based on the pictures in these instructions.

9.14. Torque the line-end to elbow fitting at the firewall to 25 ft/lbs, wrist tight.

9.15. Holding the elbow fitting with a 7/16" wrench under the dash, torque the jamb nut in the engine compartment 12 to 15 ft/lbs, light wrist tight, using an 11/16" or 3/4" socket.



- 9.16. Torque the line-end to the banjo fitting to 25 ft/lbs, wrist tight.
- 9.17. Hold the line-end and banjo fitting by hand and tighten the 5/16" Allen head banjo fitting wrist tight.
- 9.18. Install the second elbow fitting in the firewall, snugging up the jamb nut, and torque the line-ends to 25 ft/lbs.
- 9.19. Holding the elbow fitting with a 7/16" wrench under the dash, torque the jamb nut in the engine compartment 12 to 15 ft/lbs, light wrist tight, using an 11/16" or 3/4" socket.
- 9.20. Torque the line-end to the master cylinder elbow fitting to 25 ft/lbs, wrist tight.
- 9.21. Hold the line-end and elbow fitting at the master cylinder by hand and tighten the fitting nut to master cylinder light wrist tight using a 1/2" wrench.

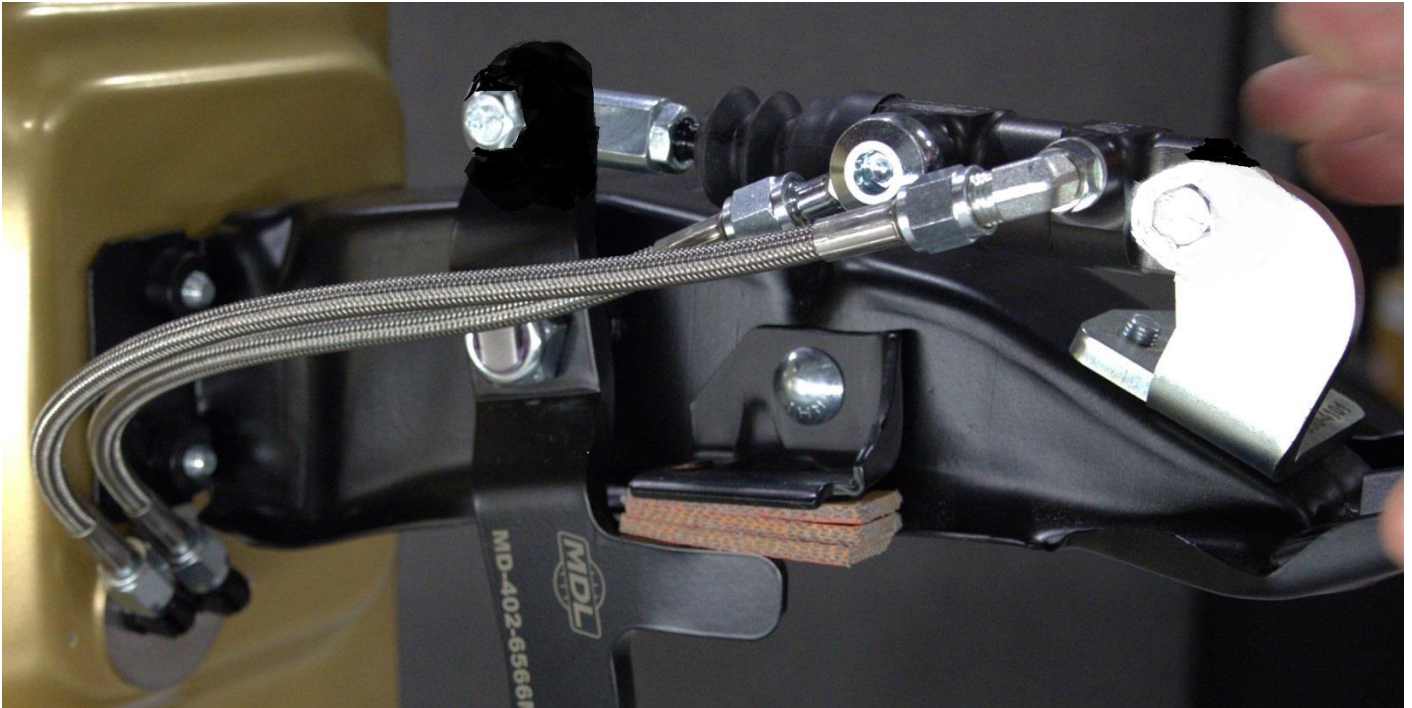

- 9.22. Cycle the clutch pedal **by hand** and check for freedom of movement. All fittings and hardware should be tight. Double-check the installation for any loose connections that may have been missed.

Finish the installation by mounting the reservoir and clamp assembly on the firewall, or bracket of your choosing. It is important the reservoir line in the engine compartment be attached to the matching fitting for the reservoir port under the dash. Use the self-tapping screws or the bolt/nut combination to mount the clamp. The clamp can slide up and down the reservoir body to a location of your choosing.



9.23. Thread the 12” braided line onto the bottom of the reservoir and the bulkhead fitting. Locate the reservoir for appearance and convenience of servicing.

9.24. Mark the location on the firewall for fasteners.

9.25. Tighten the clamp to body at the desired height using 1/8” Allen wrench. Do not over-tighten as it will distort the body and make installing the cap difficult. Loosen cap slightly and re-snug to verify it is not bound up.

9.26. Install the clamp and reservoir then remove the cap to make sure it will come on and off.

9.27. Hold the elbow fitting with a 7/16” wrench under the dash, torque the line-end to 25 ft/lbs, wrist tight.

9.28. Torque the line-end to the reservoir 15-25 ft/lbs, wrist tight. Watch for reservoir body slipping in clamp.

At this point the installation of the Stealth master cylinder system is complete. You will be left with a single AN4 open port for the line going to the slave cylinder of choice. The same instructions must be performed for attaching the braided line to the bulkhead fitting.

9.29. Re-assemble your vehicle at the dash to include the instrument cluster and steering column, if removed. Verify there is no interference of electrical wire or ducting to the Stealth system.

9.30. Remove the cardboard and re-install the seat.

## 10. Bleeding the System

10.1. In the master cylinder kit is a Bleeder Kit. Follow the *bleeder kit* instructions. If you have lost the bleeder kit instructions, they can be found on our web site [modern driveline.com](http://modern driveline.com).

**Note: The RED CAP in the reservoir is not a bladder, do not remove it.**

## 11. Driveway Test and Test Drive

- 11.1. Position rear wheels on jack stands (free to rotate). With transmission in neutral, start vehicle. Push in clutch pedal and apply brake pressure. Transmission should go into 1<sup>st</sup> gear easily. Slowly release clutch pedal. Pedal should start to engage the clutch at a comfortable level of the pedal travel (about 1.0"-1.5" from floor). It is okay if the clutch pedal releases close to the floor while on jack stands. It will release higher when the vehicle is on the ground. A new or rebuilt transmission should have all the gears run thru (in the driveway, partially releasing clutch) before road testing the new hydraulic clutch.
- 11.2. Remove jack stands and test drive. Upon return, verify steel braided line clearance and support. The hydraulic lines must be kept away from the exhaust and rotating clutch assembly.
- 11.3. If the clutch feels spongy or releases too close to the floor, repeat the bleed procedure. FYI – micro bubbles may be present in the system due to actuation, accumulation on rubber parts, and machining marks within the system.

## 12. Reminders

- 12.1. DO NOT VACUUM OR PUMP BLEED THIS SYSTEM.
- 12.2. Important: Once your new hydraulic system is active, the pedal will be immediately firm. It should not feel spongy or soft. Lack of immediate movement or a spongy feeling clutch pedal indicates air is still in the system.
- 12.3. Periodic adjustment is not required for this master cylinder system. The goal is for the clutch to re-engage in the bottom 1/3 to 1/2 of clutch pedal travel, otherwise, over-travel may occur. Once again, make sure the slave cylinder of choice is set up correctly.

## 13. Adjustments

- 13.1. Once you have confirmed all the air is out of the system it is time to discuss your adjustment options. NEVER do the below steps on jack stands; The behavior of clutch release is much different under driving conditions. Use the instructions above to make changes.
- 13.2. If the pedal is re-engaging too high up from the floor, move the rod-end attach location on the clutch pedal to the hole closest to the pivot (cross shaft). This will also make the pedal pressure a little softer.
- 13.3. If the pedal is releasing too close to the floor, or if you want assured release for racing applications, move the rod-end attach location on the clutch pedal to the hole furthest from the pivot (cross shaft). This will also make the pedal pressure a little firmer.

Note: over-stroking a slave cylinder may occur so use a volume calculator to prevent component damage. A pedal stop may also be required to prevent damage to components. Always test the stroke of the pedal and set stops accordingly.

Further assistance and tech support is available by calling Modern Driveline at 208-453-9800 M-F 8-5 Mountain time. Email – [Tech@ModernDriveline.com](mailto:Tech@ModernDriveline.com) . Please contact us first for any issues.

Enjoy your new hydraulic system and Thank You for choosing Modern Driveline.  
We appreciate your business.

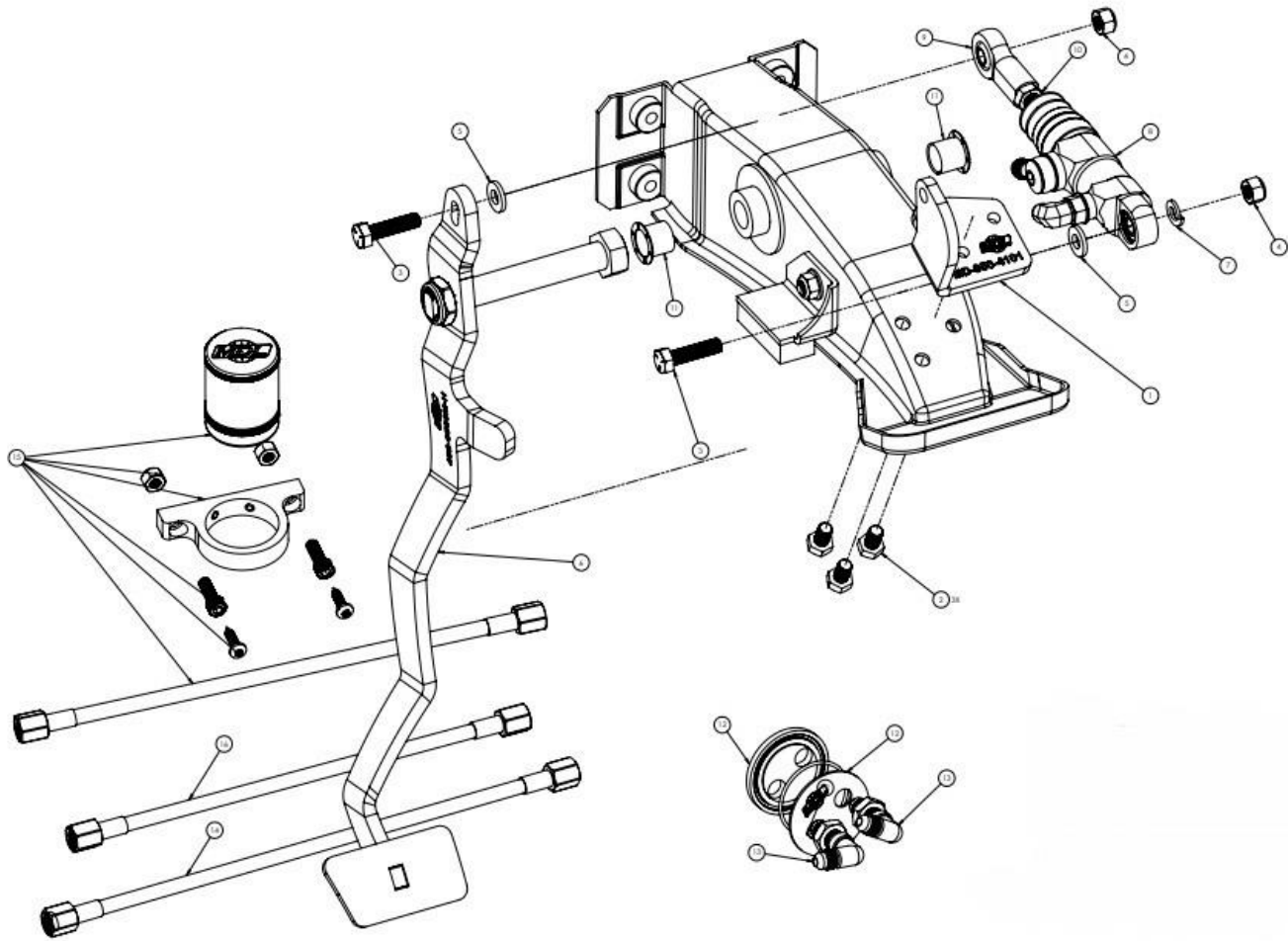

ITEM NO.	DESCRIPTION	
1	65-66 Mustang MC bracket	1
2	Bolt, Hex, 5/16-24 x .5	3
3	Bolt, hex, 5/16"-24 x 1.25	2
4	Lock Nut-5/16-24 nylock	2
5	5/16" flat washer	2
6	65-66 Mustang clutch pedal assembly for under dash hydraulic	1
7	Lockwasher, 5/16"	1
8	Tilton Master Cylinder with fittings	1
9	Ball Joint Rod End	1
10	Nut, hex, 3/8-24	1
11	Bushing-Clutch Pedal Shaft	2
12	Bulkhead Plate Assembly, 2" 2-Hole, for AN4	1
13	Precision AN 37 Degree Flared Fitting	2
14	13" uncoated braided line AN4 F-F	1
15	Reservoir & Bracket Kit, Billet Aluminum, Black	1
16	11" uncoated braided line AN4 F-F	1